

16.99 SmartShred Industrial Shredder with Integrated Feed Conveyor



intimus 16 Series Industrial Shredders have a decades long proven track record for the destruction of high volumes of paper and a wide variety of other media. The newest model in the series, the 16.99, comes equipped with a powered incline conveyor to speed and simplify feeding. For even greater convenience and versatility three discharge options are available: an integrated collection bin, an automatic baling press, or a horizontal discharge belt for use with larger collection bins or air evacuation systems.



Variant 1 - With internal waste collection bin.



Variant 2 - With integrated baling system.



Variant 2 - With discharge conveyor belt system.

16.99 Shredder Features

- Simple operation via intuitive control panel with keyed lock-out.
- The SmartShred programmable logic controller (PLC) logs operating time, displays errors and maintenance reminders
- Hardened cutter cylinders made of high-quality steel destroy even complete file folders and ensure a long service life.
- High performance through efficient, continuous feeding of documents by an automatic conveyor belt.
- An Emergency Stop bar ensures immediate shutdown in case of danger.
- The powerful, thermally protected 10 HP drive motor guarantees a smooth continuous operation.
- Paper destruction to levels P-2 or P-3 according to DIN 66399.
- The cutting unit and conveyor reverse automatically if overloaded.
- A built-in automatic oiler lubricates the cutting head to ensure optimal performance and quality.

16.99 Feed Conveyor Features

- Fully integrated into the shredder's control system.
- Belt speed 18.5 feet/min.
- Rugged steel construction with 2-layer PVC belt.
- A hinged cover for a high level of security and protection against access.

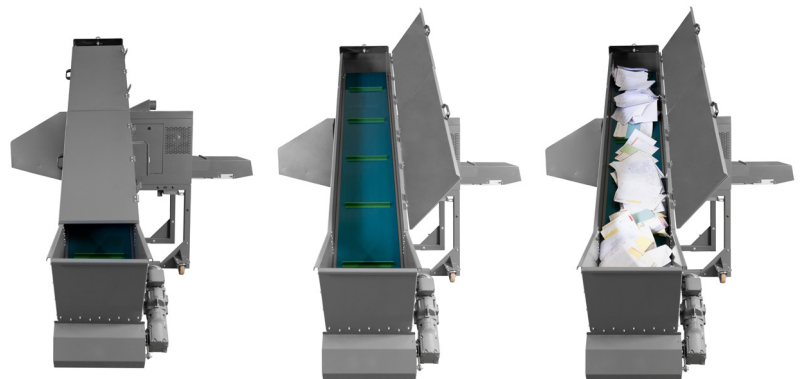

16.99 SHREDDER SPECIFICATIONS

Model	16.99 Level P-2	16.99 Level P-3
Shred Size (mm)	10 x 70	3.8 x 40
Security Levels (DIN 66399)	P-2, O-2, T-2, E-2	P-3, O-3, T-3, E-2
Cutting Head Width (in)	19.75	19.75
Waste Collection Bin (if Variant 1 chosen)	118 gallon	118 gallon
Bale Weight (if Variant 2 chosen)	130 - 175 lbs.	130 - 175 lbs.
Press Force (if Variant 2 chosen)	9 tons	9 tons
Shredding Capacity* (sheets/pass)	400 - 520	260 - 330
Shredding Capacity* (lbs./hour)	Up to 1200	Up to 1050
Sound Level dBA	61	61
Power Supply**	220/3/60	220/3/60
Motor (hp)	10	10
Weight (Variant 1/2/3)	2500/3650/2390 - lbs.	2500/3650/2390 - lbs.

*Shredding capacity varies based on paper weight. ** Other electrical configurations available.

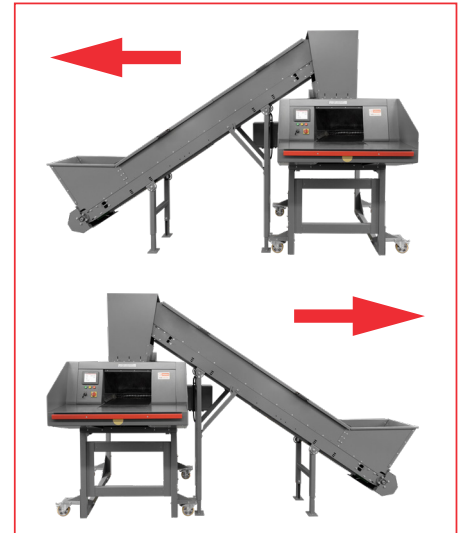

Conveyor can be positioned to the left or right side of the shredder for optimal space utilization.

16.99 DIMENSIONS BY VARIANT

Model	Variant 1 Collection Bin	Variant 2 Baling System	Variant 3 Discharge Conveyor
Overall Width (includes feed conveyor) (in)	149 inches	149 inches	149 inches
Depth (front to back) (in)	75	115 - 135 with baler flap open	101.5
Overall Height (top of conveyor feed)	92.5	92.5	92.5
Feeding Table Height (in)	48.5	48.5	48.5
Infeed Conveyor Feed Height (in)	35	35	35
Discharge Belt Height (in)	N/A	N/A	37
Discharge Belt Width (in)	N/A	N/A	22.25
Overall Conveyor Dimensions (in) (W x L x H)	25.75 x 118.25 x 92.5	25.75 x 118.25 x 92.5	25.75 x 118.25 x 92.5



Dump entire contents of waste bins onto conveyor.



Intuitive touchscreen control panel.

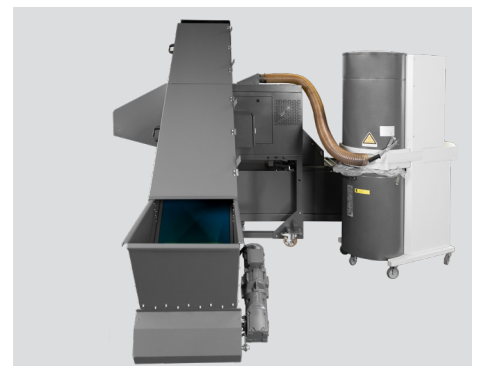

Optional dust extraction system available.

Intimus International
 251 Wedcor Avenue, Wabash, IN 46992
 1 800.775.2122 • www.intimus-direct.com

